



0808 281

3322

Compliance of relevant Health and Safety and Environmental acts is the responsibility of the hirer at all times .



These guidance notes are provided to the hirer as a reminder of their responsibility towards the operator and third parties and are not intended to be a comprehensive list of safety requirements. Reference should always be made to the manufacturer's operating instructions for further information. CP Hire GBNI Ltd accepts no liability for any loss, damage or omission arising from the operation of this item of plant

SAFETY LEAFLET FOR TELEHANDLER ATTACHMENTS



IT IS IMPORTANT TO READ THIS LEAFLET BEFORE OPERATING THIS MACHINERY

At CP Hire we value our customers and therefore provide this information to ensure the safety of all operators and to outline the effective maintenance and reliability checks necessary to ensure trouble free plant operation. It is essential that this guidance is read and understood by the Hirer before attempting to operate any plant or machinery items . It is general duty of the hirer under current health and safety legislation to provide adequate training and instruction to all employees and this information is intended to supplement that requirement. If at any time you require further information regarding any plant item please do not hesitate to contact your nearest CP Hire Branch.



Protective equipment must be worn when operating this machine



General Precautions

You must be fully trained and instructed to operate plant and equipment. You must have all information necessary to ensure safe operation of plant and equipment.

Ensure that all controls are in "neutral" position before starting engine. Ensure that proper ventilation exists when operating in buildings or areas that may become hazardous due to exhaust fumes etc.

Always wear adequate personal protection equipment (e.g. ear protection, gloves, high visibility coat, hard hat, foot protection, eye protection etc).

Report any defects immediately to your supervisor or the local CP Hire Branch.

Where Applicable:

Any plant operated on the public highway may be subject to the provisions of the Road Traffic Act and therefore, appropriate insurance must be obtained by the Hirer.

The Hirer is responsible to take all reasonable precautions to prevent theft of any plant or equipment. Such measures should include the removal of any keys when not in use and the provision of a secure area for storage when not in use (e.g. evenings and weekends) .

Hirers are responsible for insuring against any loss or damage to the equipment that may occur during the hire period.

Use of mobile phone is prohibited whilst operating this equipment

DAILY MAINTENANCE

Before Starting Work:

All Attachments

Check general condition of attachment

Check general operating ability

Grease where & if necessary

Check condition of Retaining Pins

Check all safety devices and guards.

Hydraulic attachments

Check for any fluid leaks etc.

Check condition of hydraulic hoses and quick couplings

Check controls function correctly

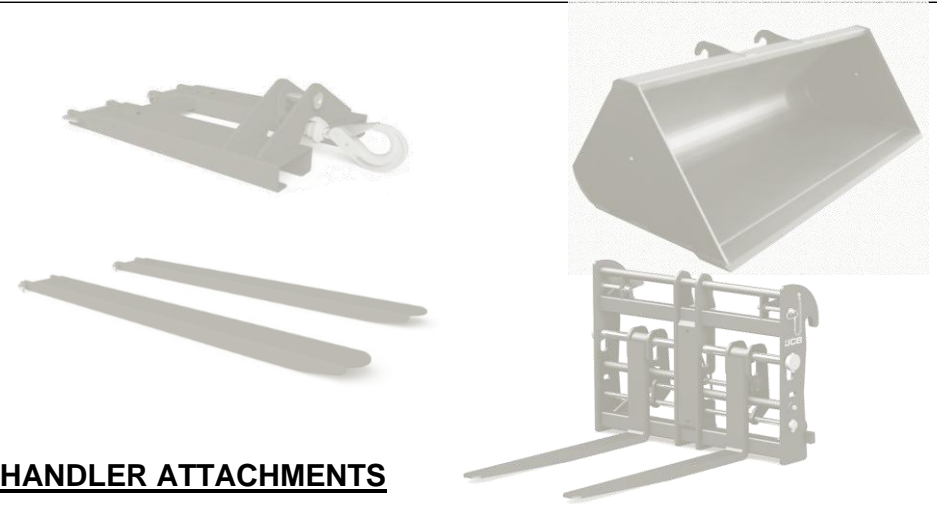

SAFETY & MAINTENANCE - TELEHANDLER ATTACHMENTS

All attachments

It is the hirer's responsibility to ensure that any person operating the equipment is properly trained, that they are in possession of the appropriate licence to operate the machine, and have all relevant information available.

Please take note and act upon any caution or warning notices that are placed upon the equipment, these could involve maintenance to ensure the effective working of the machinery

Rated lifting capacities shown are applicable with the telehandler on a firm, level surface with undamaged, properly inflated tyres. Never attempt to lift a load that is too heavy.

The attachment must never be used to lift more than the safe working load, always ensure the combined weight of the attachment and load do not exceed the machine safe working load.

Attachments should always be appropriate for the machine and fitted in a secure manner, by trained personnel

Whilst using attachments, never walk or allow any person to walk underneath the boom, always guard against loose items by using appropriate safety equipment.

Never over extend the boom on telescopic handlers fitted with attachments (refer to the manufacturer information for reference)

Always lift loads with a smooth and even movement, avoid jerking the load and sudden changes in direction

Exercise extreme caution when operating on a gradient. Beware of overhead & underground services.

Ensure that the ground conditions for operation of any equipment is suitable and fit for purpose. Compliance of the Road Traffic Act is at all times the responsibility of the hirer

Do not allow unauthorised persons to operate the equipment. Always ensure that the equipment is secure when not in use

It is the hirer's responsibility to make the equipment available for routine servicing

Hydraulic attachments

Do not attempt to use the attachment until you have ensured that all couplings are connected securely and correctly.

It is good practice to connect the return hose first, and disconnect it last to minimise or avoid trapped pressure within the attachment.

Never use your fingers to check for hydraulic fluid leaks, if a leak is suspected contact the service department for assistance.

Before disconnecting hydraulic hoses, stop the engine on the machine and operate the controls to release any trapped pressure that may be present.