



BELLE  
LIGHT  
CONSTRUCTION  
EQUIPMENT



# BWX 15/250

## BOWSER PRESSURE WASHER



BELLE  
LIGHT  
CONSTRUCTION  
EQUIPMENT



# **BWX BOWSER PRESSURE WASHER**

Heavy duty towable pressure washer comes with a 1125 litre water tank coupled to a 8.9hp Yanmar Electric-Start Diesel engine.

The robust chassis is made of 5mm hot dipped galvanised steel and is European whole Vehicle Type approved allowing for towing on public roads, making this ideal for a range of jobs.

The washers design makes it well suited for remote and harder to reach areas. The HDPE water tank also includes an internal baffle to prevent water surges whilst the machine is being towed.

Ideal for the rental market!

## **FEATURES & BENEFITS**

### **Bowser**

- Robust T-Frame chassis fully Hot dipped galvanised, European whole Vehicle Type approved.
- 1125litre / 250gallon durable Polyethylene tank, with generous 550mm hinged lockable cover. Internal baffle and filler strainer as standard.
- 2 x drain taps to allow drainage of the Pressure Washer Pump or Pump and Tank. Allows for safe transporation and prevents frost damage,
- 2 x 175R13 8ply tyres c/w moulded mudguards.
- Knott-Avonride 200kg auto reverse braked coupling, fitted with either 40mm towing eye as standard or 50mm ball option to meet your requirements.
- Lance holder integrated into the trailer complete with hose storage hooks.
- Side / front reflectors, lighting equipment complete with 13-pin plug and 7-pin adaptor.
- Break-away cable.
- Telescopic jockey Wheel / Jack.
- Forklift points for safe on-site transportation.
- LED Lightboard option available complete with 13-pin plug and 7-pin adaptor.
- High capacity 25 litre Anti-freeze tank option available.
- Gravity-fed spray bar option for on-site dust suppression.
- Customer colour options available (Tank Lid).

### **Pressure Washer**

- Robust, compact full Engine and Pump protection frame.
- Professional Yanmar diesel engine with recoil and electric start as standard.
- Accessible service points.
- Detergent / chemical feed- line complete with strainer filter.
- Inlet-line strainer for added pump protection.
- Anti-Theft Bolts securing the Pressure Washer to the chassis.
- Ignition warning system.
- High quality, heavy-duty triple piston pump.
- Professional two-wire, 10m braided hoses, complete with quick-screw adaptors and swivel couplings.
- Thermal pump protection.
- Lance comes complete with safety trigger lock.
- Specifically designed for hire and rental markets.
- Customer colour options available (Side Plates & Battery Cover).







**FORKLIFT POINTS FOR SAFE ON-SITE TRANSPORTATION**



**TANK AND PUMP DRAIN TAPS FOR SAFE TRANSPORTATION & PREVENT FROST DAMAGE**



**LANCE HOLDER INTEGRATED INTO THE TRAILER WITH HOSE STORAGE HOOKS**



**40MM TOWING EYE, BREAK-AWAY CABLE & TELESCOPIC JOCKEY WHEEL / JACK (OPTIONAL 50MM BALL HITCH ALSO AVAILABLE)**



**ANTI-THEFT BOLTS SECURING THE PRESSURE WASHER TO THE CHASSIS**



**GRAVITY-FED SPRAY BAR OPTION FOR DUST SUPPRESSION**



**LED LIGHTBOARD OPTION AVAILABLE COMPLETE WITH 13-PIN PLUG AND 7-PIN ADAPTOR**



**GENEROUS 550MM TANK MOUTH & INTERNAL TANK Baffle**



# TECHNICAL SPECIFICATIONS

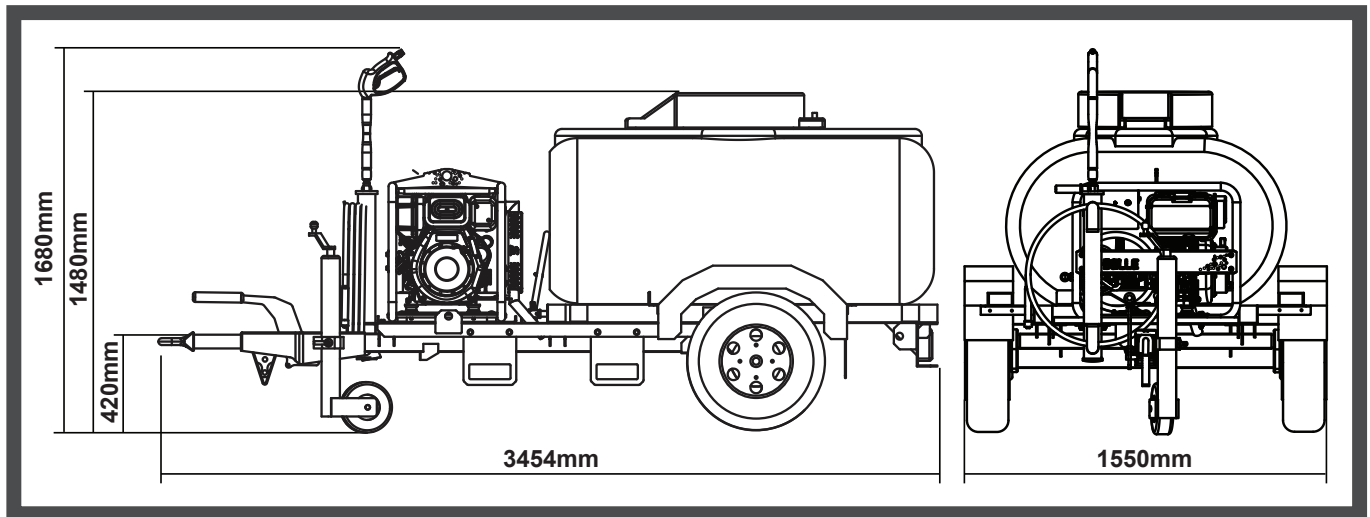

## Model

## BWX 15/250

Part No.		BWX152501DS
Unladen Weight / Max Laden Weight	(Kg)	460 / 1500
Water Tank Capacity	(Ltrs)	1125
Tyre Size	(mm)	175 x 13 -8
Tyre Pressure	(psi - bar)	60 - 4.13
*Max. Towing Speed	(mph)	60
Tow Eye Type		40mm Ring Eye
Engine		Yanmar L100 Electric Start
Engine Power	(Hp-kW)	8.9 - 6.6
Water Flow	(lpm)	15
Max. Water Pressure	(bar - psi)	250 - 3600
Max. Water Inlet Temperature	(°)	40/45
Fuel Tank Capacity	(Ltrs)	5.4
Hose Length	(M)	10
Gearbox Driven Pump		Yes
Vibration Level	(m/sec <sup>2</sup> )	< 2.5
Sound Power Level	(dB(A))	109

## Options

OPPW/01/FIO	50mm Tow Ball
OPPW/03/DIO	LED Lightboard
OPPW/04/DIO	Gravity-Fed Spray Bar
OPPW/05/DIO	Anti-Freeze Tank



ALTRAD BELLE  
 Sheen, Nr. Buxton, Derbyshire, SK17 0EU, GB  
 Tel. +44 (0)1298 84606 - Fax +44 (0)1298 84722 - Email: sales@altrad-belle.com  
[www.Altrad-Belle.com](http://www.Altrad-Belle.com)  
[www.ALTRAD-Belle247.com](http://www.ALTRAD-Belle247.com)