

USER GUIDE

# AUTOLOCK TIPPING SKIP

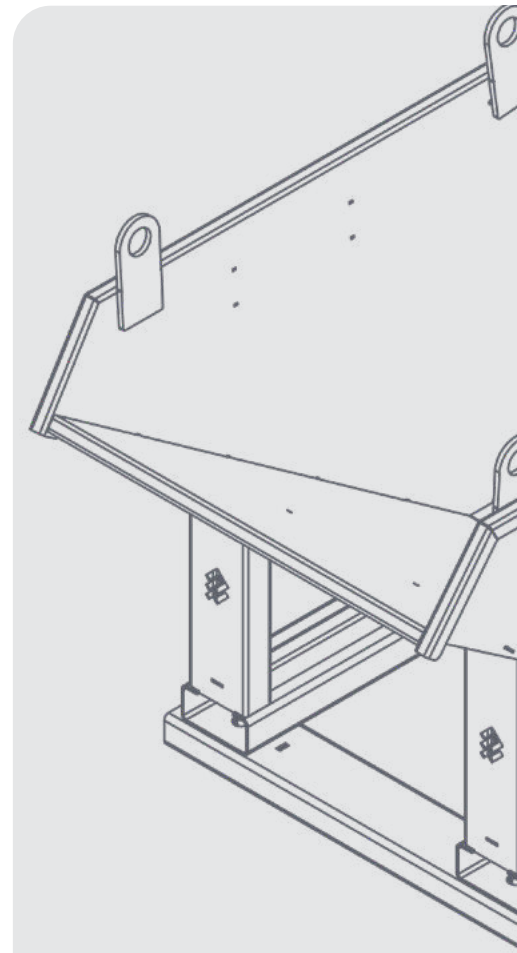

# DISCLAIMER

Do not attempt to handle or operate this equipment before you have received sufficient training. Before use, operatives must have carried out all checks featured on the Visual Inspection Sheet on page 19. It is imperative that you have read the General Safety Instructions on page 20 and sufficiently familiarised yourself with the Operational Procedures in this document.

Note that this item is compliant only to the standards specified in this User Guide and it is therefore the duty of the responsible person(s) to review and ensure compliance.

# CONTENTS

## PRODUCT INFORMATION

INTRODUCTION	04
SPECIFICATION	05
PARTS DIAGRAM	08

## OPERATIONAL PROCEDURES

IMPORTANT USAGE NOTES	12
USE WITH A TELEHANDLER	12
USE WITH A CRANE	14
USE WITH AN EXCAVATOR	15

## MAINTENANCE & INSPECTION

MAINTENANCE REGIME	18
VISUAL INSPECTION SHEET	19

## GENERAL SAFETY INSTRUCTIONS

SAFETY INSTRUCTIONS	20
GENERAL NOTES	21

## LEGAL

TERMS AND CONDITIONS	22
EC DECLARATION OF CONFORMITY	26
STANDARDS AND REGULATIONS APPLICABLE	27

# INTRODUCTION

## OVERVIEW

The Conquip Autolock Tipping Skip is the choice for many sites and leading plant companies. Its primary function is for the transportation of waste material. Autolocks cannot be accidentally tipped, as these skips are emptied by adjusting the angle of the telehandler's forks.

A gas assisted ram ensures the skip automatically locks to the forks and its unique design guarantees 100% restraint on the forks. Simply drive your forks into the skip's fork pockets and raise it off the ground. The Autolock mechanism will clamp itself to the fork tines. To detach it, simply land the skip and the Autolock mechanism will release, enabling you to reverse away.

Designed for use with forklifts and telehandlers, these skips are heavy-duty to withstand the daily rigours of construction sites and thoroughly tested to ensure they are built to last.

## KEY BENEFITS

- Autolock system eliminates the need to attach safety restraint chains.
- Utilising the telehandlers' tilt function to tip the load ensures that the Autolock cannot be accidentally tipped.
- No levers or cables are required to discharge the Autolock so the driver can remain safely seated within the cab.
- Standard width fork pockets reduces the need to adjust forks.
- Designed and manufactured within the United Kingdom from British and European steel.

## CUSTOMISATION OPTIONS

- Available with castor wheels (these consist of two swivel wheels for the front and two fixed wheels for the rear).
- Painted in the Institute of Civil Engineers standard colours of your choice (see colour chart right).
- Crane lift models available.
- Mesh sides variation available.
- Customer branding.

COLOUR	USE
	Asbestos
	Hazardous
	Clinical
	Plasterboard
	Inert
	Mixed
	Metal
	Wood
	Packaging

# SPECIFICATION

## THE RANGE



CODE	TYPE	WEIGHT (kg)	WLL* (kg)	CAPACITY (litres)
FA800AC-00500	Standard Autolock 500	125	1000	500
FA801-00500	Standard Autolock with Castors 500	160	1000	500
CA128-00500	Cranelift Autolock 500	130	1000	500
CA134-00500	Cranelift Autolock with Castors 500	165	1000	500
FA800AC-01200	Standard Autolock 1200	150	2000	1200
FA801-01200	Standard Autolock with Castors 1200	185	2000	1200
FA800AH-01200	Standard Autolock with Mesh Sides 1200	175	1000	1200
CA128-01200	Cranelift Autolock 1200	155	1000	1200
CA134-01200	Cranelift Autolock with Castors 1200	190	1000	1200

\*Working Load Limit

# SPECIFICATION

## STANDARD AUTOLOCK

ITEM	PRODUCT CODE
Standard Autolock 500	FA800AC-00500
Standard Autolock with Castors 500	FA801-00500
Standard Autolock 1200	FA800AC-01200
Standard Autolock with Castors 1200	FA801-01200
Standard Autolock with Mesh Sides 1200	FA800AH-01200

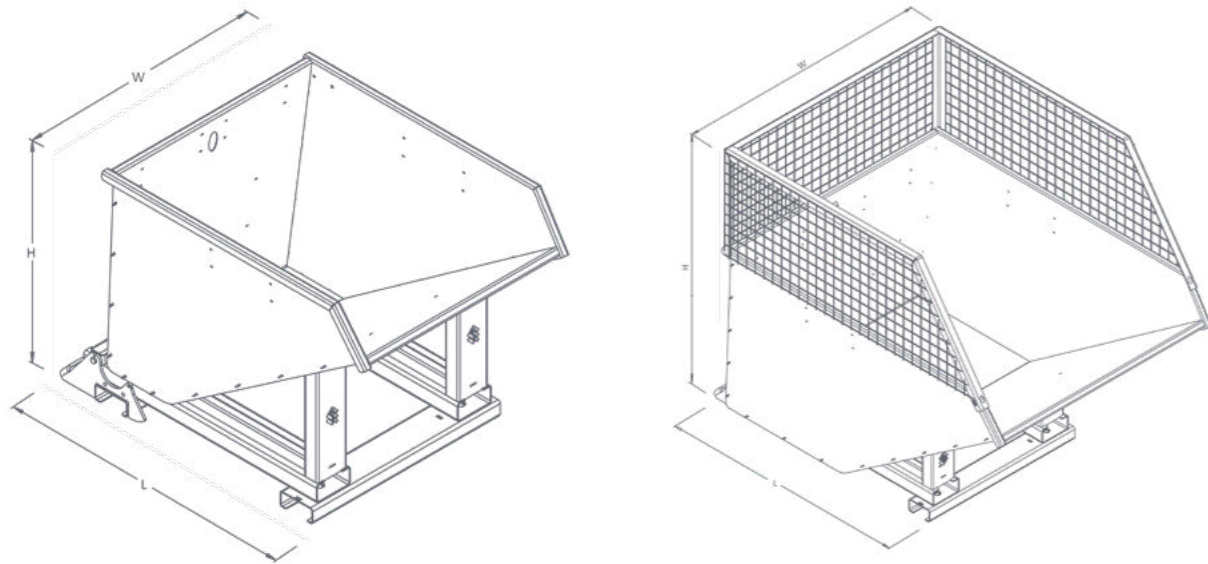

LENGTH (mm)	WIDTH (mm)	HEIGHT (mm)
1400	920	934
1400	989	1023
1818	1224	964
1818	1224	1051
1846	1248	1464

# SPECIFICATION

## CRANELIFT AUTOLOCK

ITEM	PRODUCT CODE
Cranelift Autolock 500	CA128-00500
Cranelift Autolock with Castors 500	CA134-00500
Cranelift Autolock 1200	CA128-01200
Cranelift Autolock with Castors 1200	CA134-01200

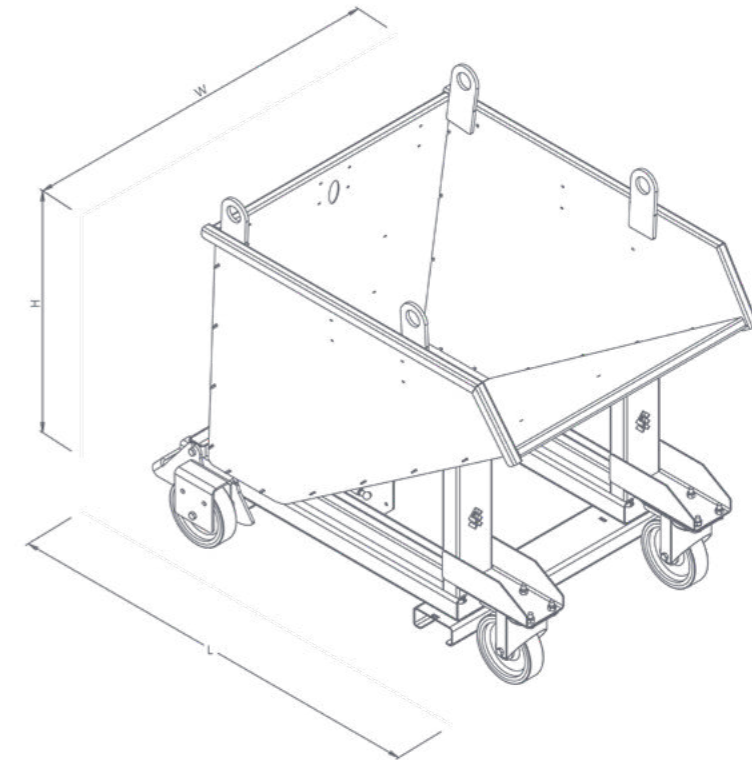

LENGTH (mm)	WIDTH (mm)	HEIGHT (mm)
1400	920	1050
1400	989	1138
1818	1224	1078
1818	1224	1160

# PARTS DIAGRAM

## STANDARD & CRANELIFT 500

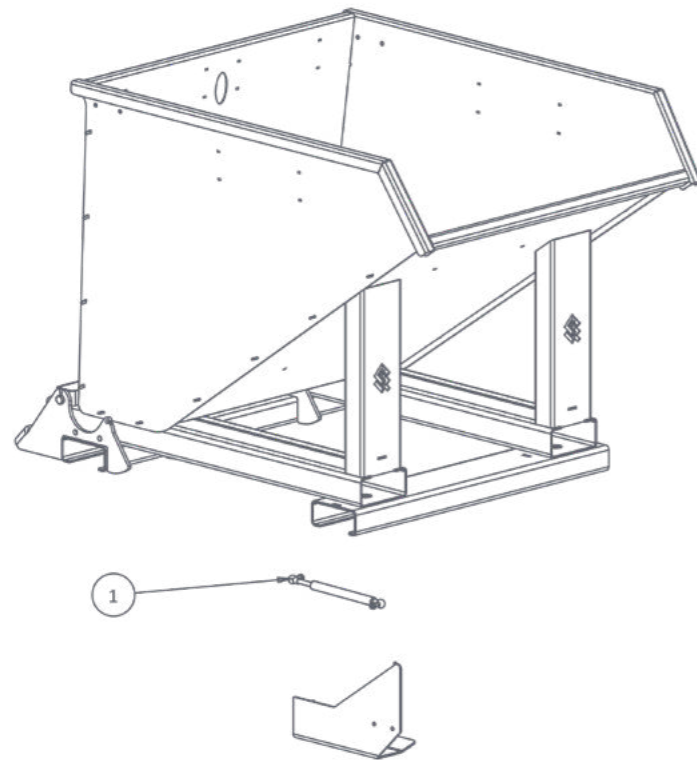

ITEM NUMBER	PART	DESCRIPTION	QUANTITY
1	ZZ110015	Gas Strut	1

NOTE: These parts are for this model, they may differ for previous versions. Please contact Conquip with any queries.

# PARTS DIAGRAM

## STANDARD & CRANELIFT 500 WITH CASTORS

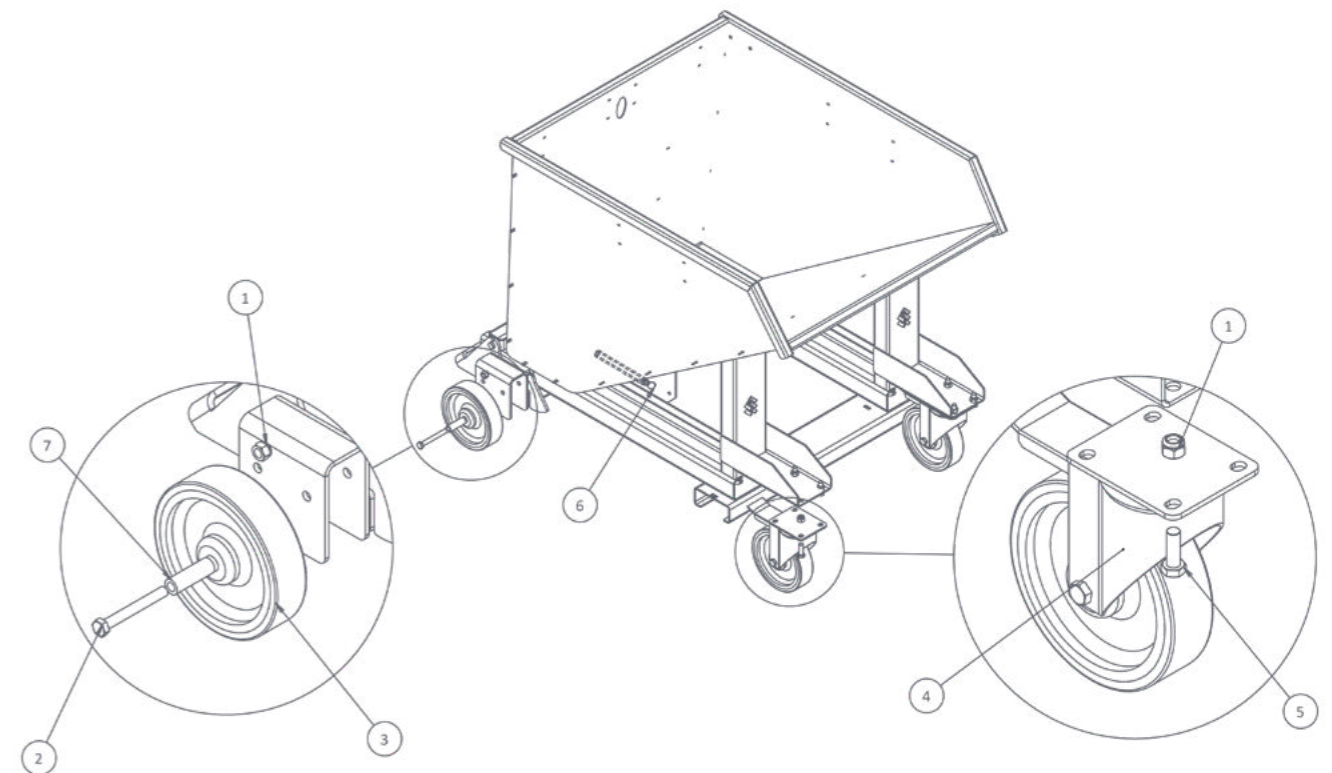

ITEM NUMBER	PART	DESCRIPTION	QUANTITY
1	NS800015	M12 Nyloc Nut	10
2	NS800234	M12 x 100 Hex Head Set Screw	2
3	ZZ110098	200mm Polyurethane Wheel	2
4	ZZ110097	Swivel Castor with Brakes 200mm	2
5	NS800014	M12 x 35 Hex Head Set Screw	8
6	ZZ110015	Gas Strut 400mm to 250mm	1
7	ZZ110110	Tube Infill for 200mm Poly Wheel	4

NOTE: These parts are for this model, they may differ for previous versions. Please contact Conquip with any queries.

# PARTS DIAGRAM

## STANDARD & CRANELIFT 1200

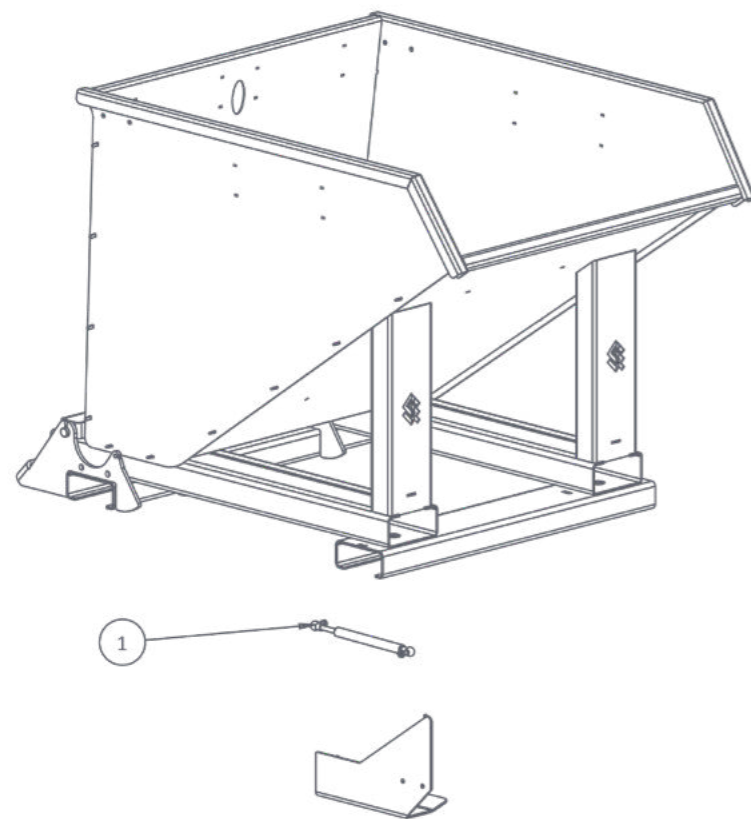

ITEM NUMBER	PART	DESCRIPTION	QUANTITY
1	ZZ110015	Gas Strut	1

NOTE: These parts are for this model, they may differ for previous versions. Please contact Conquip with any queries.

# PARTS DIAGRAM

## STANDARD & CRANELIFT 1200 WITH CASTORS

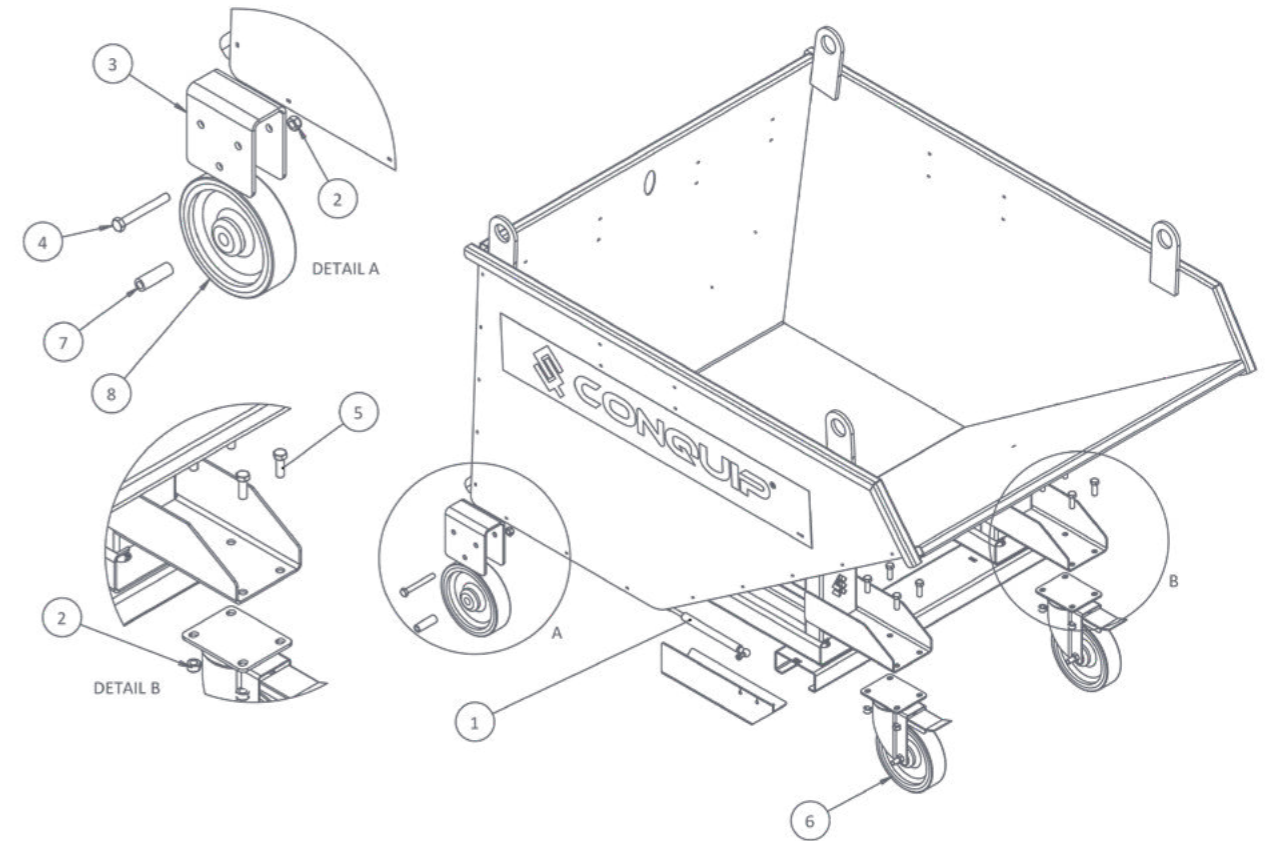

ITEM NUMBER	PART	DESCRIPTION	QUANTITY
1	ZZ110015	Gas Strut	1
2	NS800015	M12 Nyloc Nut	10
3	ZZ110148	Rear Castor Bracket	2
4	NS800234	M12 x 100 Hex Head Set Screw	2
5	NS800014	M12 x 35 Hex Head Set Screw	8
6	ZZ110097	Swivel Braked Castor Wheel 200mm Ø	2
7	ZZ110110	Tube 61 x 20(ODØ) 12(IDØ)mm	2
8	ZZ110098	Polyurethane Wheel 200mm Ø	2

NOTE: These parts are for this model, they may differ for previous versions. Please contact Conquip with any queries.

# OPERATIONAL PROCEDURES

## IMPORTANT USAGE NOTES

- Ensure the work area is clear of all obstructions.
- Check that the skip is suitably rated to lift the load and of the correct size.
- Ensure adequate room around the unit for the operator to work safely.
- Use a suitably rated 4-leg lifting chain, with self-locking hooks.
- Take care not to tangle the chains when attaching to the skip.
- Always use a signaller who can clearly communicate with the crane operator.

## USE WITH A TELEHANDLER

01. Set the telehandler's forks to the correct width for the skip's fork pockets. Make sure that they are equidistant from the centre carriage.
02. Drive the telehandler to the skip, aligning the forks with the skip's fork pockets.
03. Double check that all is correctly aligned, then move the telehandler forward until the forks are fully inserted into the fork pockets.
04. Raise the skip just off the ground to activate the Autolock mechanism. Once the mechanism has snapped into place (see Autolock Mechanism Instructions on page 14 for details), the skip is secure on the forks.
05. Fill the skip with materials ensuring not to overload the skip.
06. Once ready, clear all personnel from the work area. Raise the unit just enough to allow sufficient clearance from the ground when traveling.



07. Drive the telehandler to the discharge area. If discharging into a traditional skip, raise the unit so that it clears the walls of the skip then drive forward until positioned over the skip.

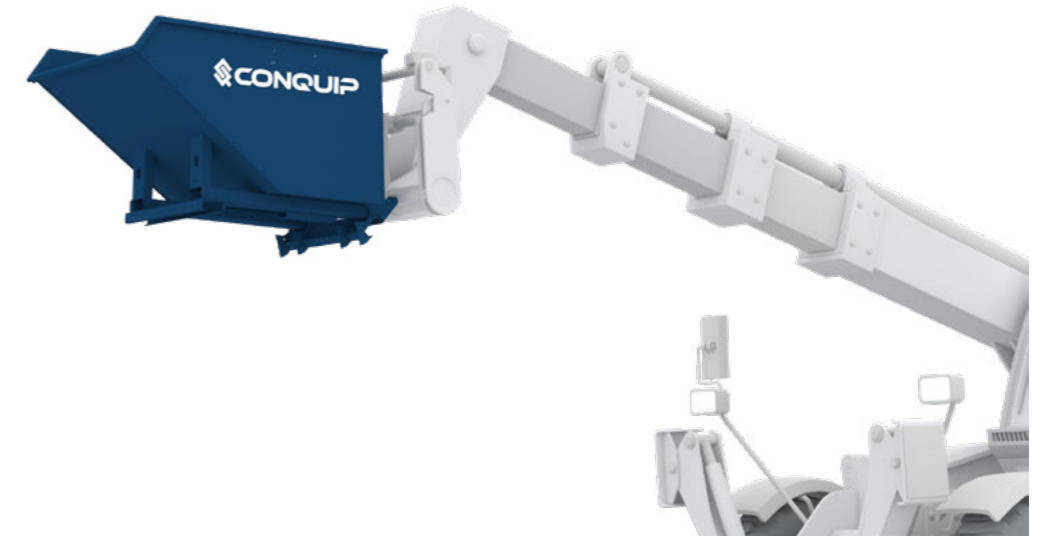

08. Using the tilt function on the telehandler, empty the skip of its contents, return the skip to the horizontal position, return to the loading area.



09. The skip can be removed from the telehandler simply by landing on level ground and reversing away.

### AUTOLOCK MECHANISM INSTRUCTIONS

Insert the forks fully into the fork pockets and raise the skip off the ground. Upon lifting, the Autolock mechanism will automatically rise onto the locked position.

**IMPORTANT:** If the skip cannot be secured correctly do not continue and contact Conquip Engineering Group for advice. Only fill the skip when it is fully lowered to the ground. Fill the skip ensuring the load is no wider, longer or higher than the skips side walls. Do not overload by volume or by weight.



### USE WITH A CRANE

01. Connect the 4-leg lifting chain to the 4 lifting eyes on the skip.
02. Once the chains are secured, carry out a test lift. Then the crane operator should lift the skip and transport to the correct location on site.
03. The Autolock Tipping Skip cannot be emptied via a crane. Once lowered to the ground, detach the chains and use a telehandler or an excavator fitted with Conquip Excavator Forks to empty the skip.

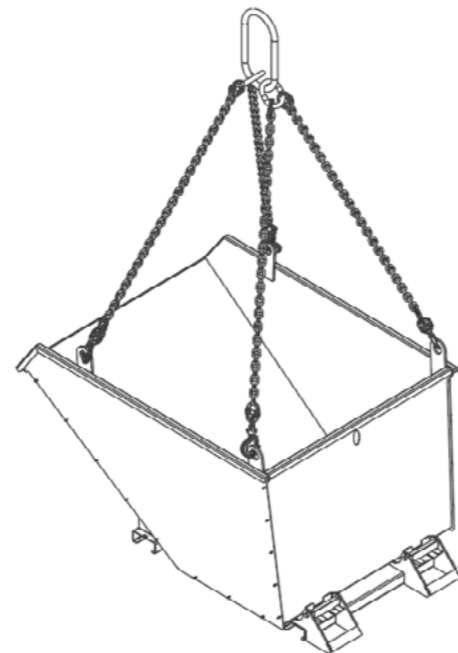

### USE WITH AN EXCAVATOR

01. The Autolock Tipping Skip is designed for use with forklifts and telehandlers. However, it can be used with excavator forks providing they are compatible.
02. Check the set of excavator forks on site are compatible with the excavator. It is recommended to use Conquip Excavator Forks. See table on page 16 for the fork tine dimensions of Conquip's Excavator Forks.
03. Raise the unit off the ground so the fork tines sit in the lowest position of the excavator forks frame.

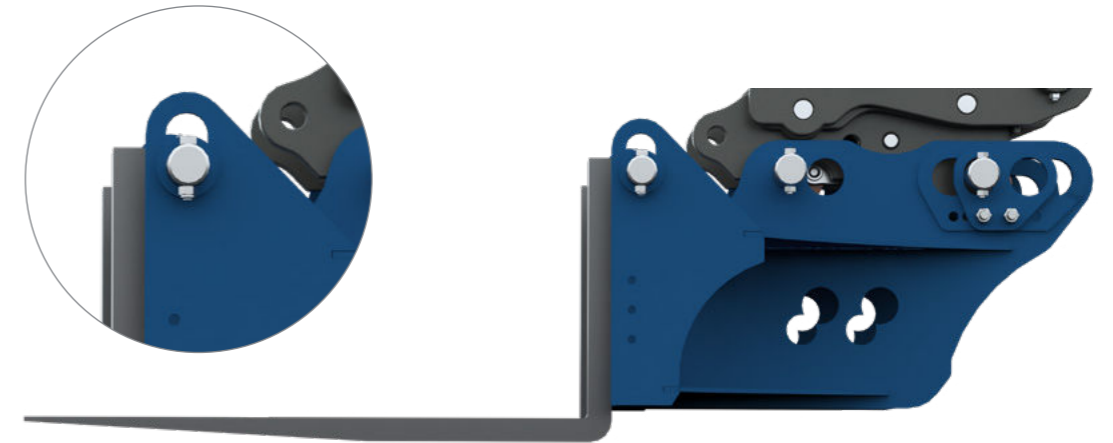

04. Measure the fork tines to ensure there is a minimum of 100mm between the base of the frame and the base of the fork tine. This applies to both fixed and floating fork variations. This 100mm allows enough space for the Autolock mechanism to lock into place as the skip is raised off the ground.



05. Set the excavator forks to the correct width for the skip's fork pockets. Make sure that they are equidistant from the centre carriage.

06. Insert the forks into the Autolock Tipping Skip's fork pockets. The face of the fork must make contact with the rear of the fork pocket.

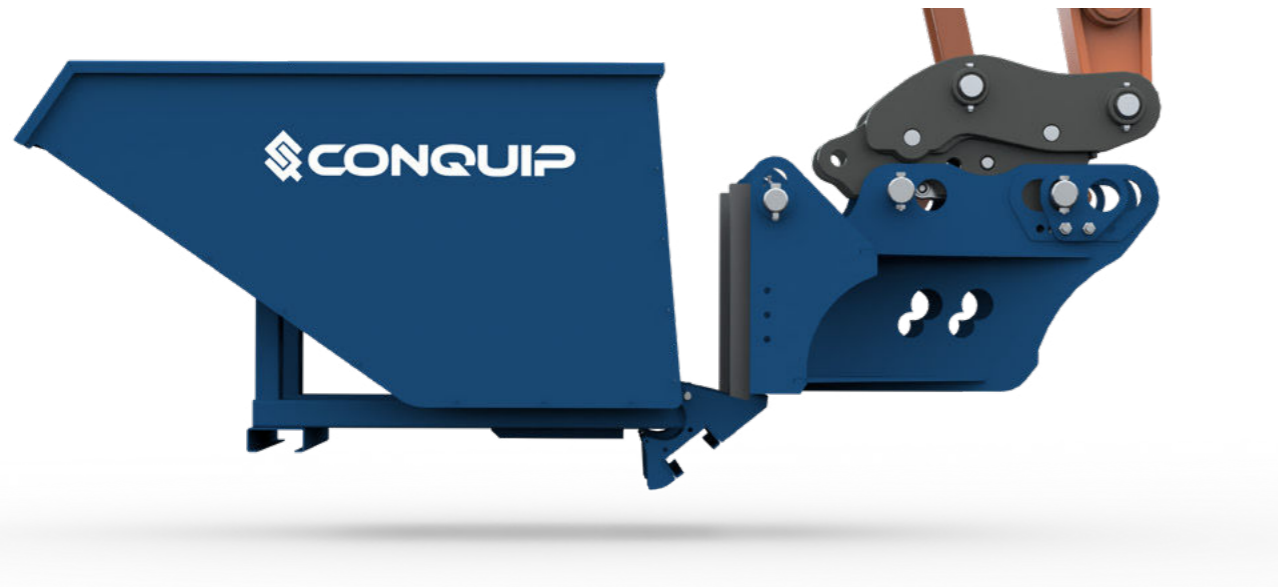

07. Check the excavator forks are compatible with the Autolock Tipping Skip by performing a test lift to ensure that the Autolock mechanism is fully engaged with the heel of the forks. Ensure all personnel are clear before lifting the skip. The skip should remain locked on the forks as it is tipped forwards.



### CONQUIP EXCAVATOR FORK TINES



TYPE	LENGTH (L) (mm)	WIDTH (W) (mm)	HEIGHT (H) (mm)	THICKNESS (T) (mm)
1-tonne	1000	80	390	45
2.5-tonne	1200	100	550	40
4-tonne	1200	100	560	50

# MAINTENANCE & INSPECTION

## MAINTENANCE REGIME

- It is mandatory that the machinery equipment is thoroughly examined regularly, by a qualified engineer, to ensure compliance with relevant regulations. Conquip recommend carrying out a thorough examination every six months.
- This machinery may incorporate various loose and detachable items including, but not limited to pins, bolt assemblies and adaption plates. Refer to the separate requirements for the safe use of those items.
- When not being used, store the unit in a clean, upright condition and in a safe place where it will be protected from thieves and unauthorised users.
- This machinery must be inspected by the responsible person before each use and then regularly, as determined by your risk assessment or working practice. If you have any concerns about the machinery's condition or suitability, do not use it.

## VISUAL INSPECTION CHECKLIST

INSPECTION ITEMS	RESULTS		COMMENTS
	PASS	FAIL	
Serial Number			CQ.....
Product Code			
Working Load Limit (Kg)			
Conforms to user guide specification			
Check if the base of the skip is bent or distorted			
Check for sharp edges and file any down before use			
Ensure heel locking mechanism secures skip to machine's fork tines when raised			
Inspect fork pocket welds for cracks, distortion, or rust around the joints			
Ensure the ID plate is visible and all information is legible			
Check condition of castor wheels and they are rotating freely (if applicable)			
Check lifting points to ensure there are no bends or distortion (if applicable)			
Ensure operational procedures in your site's RAMs are in line with the guidance in this user guide			
Carry out a general visual inspection checking the side and back panels for bends or splits			
Perform a test lift to check the operation of the skip to ensure it is fit for purpose			
<b>SIGNATURE</b>			
Name	Position	Qualification	Signature & Date

# GENERAL SAFETY INSTRUCTIONS

The machinery should be properly operated and maintained to keep it in a safe, efficient operating condition. Be sure that all fixings and components are free of mud or other matter that might cause issues hazardous to the operator, serviceman, or other personnel or equipment. Report all malfunctions to those responsible for maintenance, and do not operate the equipment until corrected. Normal service or maintenance performed as required can prevent unexpected and unnecessary downtime.

This operations manual describes general inspections, servicing and operation with the normal safety precautions required for normal servicing and operating conditions. It is not a guide, however, for abnormal conditions or situations, and therefore, servicemen and operators must be safety conscious and alert to recognise potential servicing or operating safety hazards at all times, and take necessary precautions to assure safe servicing and operation of the machine.



**M002**  
Refer to instructions manual



**M004**  
Wear eye protection



**M008**  
Wear safety footwear



**M009**  
Wear protective gloves



**M010**  
Wear protective clothing



**M014**  
Wear head protection



**M015**  
Wear high-visibility clothing

## GENERAL NOTES

- Read this operations manual and learn the operating characteristics and limitations of the machinery. Know what operating clearances the machine requires.
- Read and understand all the safety signs prior to operation.
- If the safety signs are obstructed by dirt or debris, clean them using mild soap and water prior to operation.
- If the safety signs are damaged or illegible, replace them immediately, prior to operation.
- Be aware of operating hazards that weather changes can create on the job. Know proper procedures to follow when a severe rain or electrical storm strikes.
- Never attempt to operate or work on machinery when not feeling physically fit.
- Never wear loose clothing, rings, watches, heavy gloves etc., that might catch and result in injury.
- Know what safety equipment is required and use it. Such equipment may be: hard hat, safety glasses, reflector type vests, protective gloves and safety footwear.

# TERMS & CONDITIONS

## CONQUIP ENGINEERING GROUP STANDARD PRODUCT WARRANTY

### 01. COMMENCEMENT

1.1 This Warranty shall commence on the Commencement Date and shall continue until the earlier of:

- (a) the Expiry Date; or
- (b) the date on which it may be voided in accordance with clause 4.1(b)

when it shall terminate automatically without notice.

### 02. DUTY OF GOOD FAITH

2.1 The Purchaser shall in the exercise of its rights under this Warranty and in the compliance with its obligations under this Warranty be subject to and shall in all respects owe and comply with a duty of good faith to the Warrantor.

### 03. NATURE AND EXTENT OF COVER

3.1 Subject to clause 3.2 the Warrantor agrees and undertakes to the Purchaser that it shall be liable to the Purchaser under and in accordance with the terms of this Warranty in the event that:

- (a) prior to the Expiry Date the Purchaser shall notify a Warranty Claim to the Warrantor; and
- (b) the Equipment or any relevant part of the Equipment shall have become unusable as the result of defective material or defective workmanship prior to the Expiry Date.

3.2 The Warrantor's obligation under clause 3.1 shall be expressly subject to the provisions of clauses 4, 5 and 6 and conditional upon the Purchaser's compliance in full with the provisions of clause 7.

### 04. RESTRICTIONS

4.1 The following restrictions apply to this Warranty:

(a) This Warranty is personal to the Purchaser and neither the legal benefit nor legal burden of this warranty may be assigned or novated or otherwise transferred by the Purchaser to any other party. Any purported assignment, novation or transfer shall not be skipping upon the Warrantor.

(b) This Warranty shall be void in the event that the Purchaser:

(i) cannot provide authentic and original documentary evidence that the Purchaser has during the period between the Commencement Date and the Expiry Date complied with the Maintenance and Servicing Requirements; and/or

(ii) has, during the period between the Commencement Date and the Expiry Date, exceeded the Purchaser's Usage Cycle Parameters; and/or

(iii) has, during the period between the Commencement Date and the Expiry Date, exceeded the Purchaser's Use Parameters; and/or

(iv) has carried out, or procured the carrying out by any third party of, any repair to the Equipment or any part of the Equipment which is not an Authorised Repair; and/or

(v) has operated the Equipment after having replaced any part of the Equipment with a part which has not been supplied and fitted by the Warrantor; and/or

(vi) has modified the Equipment in any way prior to use.

### 05. EXCLUSIONS

5.1 The following are excluded from the scope of this Warranty:

(a) Loss of and/ or damage to the Equipment or any part of it resulting from any collision between the Equipment and any other fixed or stationary or mobile object whatsoever, irrespective of whether that collision was or was not caused by the Purchaser; and/or

(b) Loss of and/or damage to any personal property and/or possessions or other equipment not forming part of the Equipment but which is present in or about the Equipment; and/or

(c) loss and/or damage which is covered by any other insurance policy taken out and maintained by the Purchaser or in respect of which the Purchaser has a contractual obligation to do so; and/or

(d) loss and/or damage to the equipment which is consistent with the use by the Purchaser of the Equipment:

(i) in compliance with the Maintenance and Servicing Requirements; and

(ii) in compliance with the Usage Cycle Parameters; and

(iii) in compliance with the Use Parameters; and

(iv) having only carried out Authorised Repairs to the Equipment; and

(v) having all and any replacement parts fitted by the Warrantor; and

(vi) in unmodified form.

## 06. LIMITATION OF LIABILITY

6.1 The Warrantor's liability to the Purchaser shall be limited as follows:

- (a) The Warrantor shall not in any circumstances be liable to the Purchaser for indirect and/or consequential and/or economic loss suffered and/or incurred as the case may be by the Purchaser; and
- (b) The Warrantor shall only be liable to the Purchaser for the reasonable and proper costs reasonably and properly incurred by the Purchaser directly in connection with the repair and/or replacement (at the Warrantor's absolute discretion) of the Equipment or any part of the Equipment; and
- (c) The Warrantor's liability to the Purchaser shall notwithstanding any other provision of this Warranty, not in any circumstances exceed the Purchase Price of the Equipment.

## 07. WARRANTY CLAIMS

7.1 The Purchaser shall in respect of any claim against the Warrantor under this Warranty and within 24 hours of the occurrence of the subject matter of the Warranty Claim:

- (a) Complete in full and submit to the Warrantor a Warranty Claim in the form annexed to Schedule 4;
- (b) Provide date stamped or date identifiable photographs evidencing the claim; and
- (c) Make the Equipment or the relevant part of the Equipment available to the Warrantor for inspection within 48 hours of notification of the relevant Warranty Claim.

## 08. ENTIRE AGREEMENT

8.1 This Warranty constitutes the entire agreement between the parties and supersedes and extinguishes all previous promises, assurances, warranties, representations and understandings between them, whether written or oral, relating to its subject matter.

8.2 Each party agrees that it shall have no remedies in respect of any statement, representation, assurance or warranty (whether made innocently or negligently) that is not set out in this Warranty. Each party agrees that it shall have no claim for innocent or negligent misrepresentation or negligent misstatement based on any statement in this Warranty.

No variation of this Warranty shall be effective unless it is in writing and signed by the parties (or their authorised representatives).

## 09. WAIVER

No failure or delay by a party to exercise any right or remedy provided under this Warranty or by law shall constitute a waiver of that or any other right or remedy, nor shall it prevent or restrict the further exercise of that or any other right or remedy. No single or partial exercise of such right or remedy shall prevent or restrict the further exercise of that or any other right or remedy.

## 10. SEVERANCE

10.1 If any provision or part-provision of this Warranty is or becomes invalid, illegal or unenforceable, it shall be deemed deleted, but that shall not affect the validity and enforceability of the rest of this Warranty.

10.2 If any provision or part-provision of this Warranty is deemed deleted under clause 10.1 the parties shall negotiate in good faith to agree a replacement provision that, to the greatest extent possible, achieves the intended commercial result of the original provision.

## 11. THIRD PARTY RIGHTS

11.1 This Warranty does not give rise to any rights under the Contracts (Rights of Third Parties) Act 1999 to enforce any term of this Warranty.

## 12. GOVERNING LAW

12.1 This Warranty and any dispute or claim (including non-contractual disputes or claims) arising out of or in connection with it or its subject matter or formation shall be governed by and construed in accordance with the law of England and Wales.

## 13. JURISDICTION

13.1 Each party irrevocably agrees that the courts of England and Wales shall have exclusive jurisdiction to settle any dispute or claim (including non-contractual disputes or claims) arising out of or in connection with this Warranty or its subject matter or formation.

# EC DECLARATION OF CONFORMITY

## IN ACCORDANCE WITH EN ISO 17050-1:2004

Declaration: As defined by the Machinery Directive 2006/42/EC and subsequent amendments

We, CONQUIP ENGINEERING GROUP, herewith declare that the following indicated equipment meets the fundamental health and safety requirements concerning the EU guideline(s), due to their design and manufacture.

This declaration will be rendered null and void if the machine is changed without our approval.

**SIGNED:**



**DATED: 2025**

Garry Critchley, Managing Director

PRODUCT CODES	GENERAL DESCRIPTION / DESIGNATION:	WORKING LOAD LIMIT:
FA800AC-00500	Standard Autolock 500	1000kg
FA801-00500	Autolock with Castors 500	1000kg
CA128-00500	Cranelift Autolock 500	1000kg
CA134-00500	Cranelift Autolock with Castors 500	1000kg
FA800AC-01200	Standard Autolock 1200	2000kg
FA801-01200	Autolock with Castors 1200	2000kg
FA800AH-01200	Standard Autolock with Mesh Sides 1200	1000kg
CA128-01200	Cranelift Autolock 1200	1000kg
CA134-01200	Cranelift Autolock with Castors 1200	1000kg

ITEM	CODE	DESCRIPTION
<b>EC DIRECTIVE / REGULATION</b>	2006/42/EC	Directive 2006/42/EC- new machinery directive
<b>HARMONISED STANDARDS</b>	BS EN ISO 12100:2010	Safety of machinery General principles for design Risk assessment and risk reduction
	BS EN 1993-1-1: 2005	Eurocode 3. Design of steel structures General rules and rules for buildings
<b>OTHER REGULATIONS</b>	LOLER 1998	Lifting Operations and Lifting Equipment Regulations 1998 (LOLER)
	PUWER 1998	Provision and Use of Work Equipment Regulations 1998 (PUWER)

TALKING TO US IS EASY  
**WE'RE HERE TO HELP**

Call us on 0333 300 3470  
Email us at [sales@cqegroup.com](mailto:sales@cqegroup.com)  
[www.cqegroup.com](http://www.cqegroup.com)

