

TECHNICAL DATA

TANDEM ROLLERS

BW 135 AD-5, BW 138 AD-5

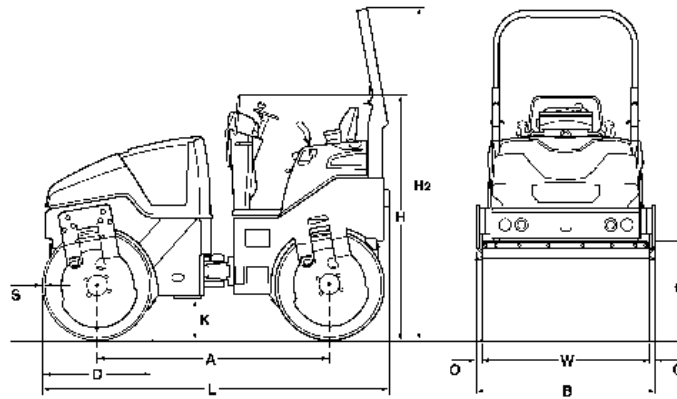



Dimensions in mm

	A	B	C	D	H	H2	K	L	O	S	W
BW 135 AD-5	1900	1390	700	900	1900	2700	340	2840	44	16	1300
BW 138 AD-5	1900	1468	700	900	1900	2700	340	2840	44	18	1380

Shipping dimensions in m3

BW 135 AD-5
BW 138 AD-5

without ROPS

7,500
 7,921

with ROPS

10,659
 11,257

Machine type	Compaction output (m3/h) at recommended soil layer thicknesses		
	Gravel, sand	Mixed soil	Silt, clay
BW 135 AD-5	90-180	70-140	40-80
BW 138 AD-5	100-200	80-160	40-80

Machine type	Compaction output (t/h) at different asphalt layer thicknesses		
	2-4 cm	6-8 cm	10-14 cm
BW 135 AD-5	30-55	50-85	75-130
BW 138 AD-5	30-55	50-90	75-135

Technical Data

BOMAG BW 135 AD-5

BOMAG BW 138 AD-5

Weights

Operating weight w. ROPS CECE	kg	4.050	4.500
Average static linear load CECE	kg/cm	15,6	16,3
Grossweight	kg	5.500	5.500

Dimensions

Working width	mm	1.300	1.380
Track radius, inner	mm	2.665	2.616

Driving Characteristics

Speed	km/h	0- 10,0	0- 10,0
Working speed with vibration	km/h	0- 10,0	0- 10,0
Max. gradeability without/with vibr.	%	40/30	40/30

Drive

Engine manufacturer		Kubota	Kubota
Engine type		V2403	V2403
Emission stage		Stage V / TIER4f	Stage V / TIER4f
Exhaust gas aftertreatment		DPF	DPF
Cooling		water	water
Number of cylinders		4	4
Performance ISO 14396	kW	34,1	34,1
Performance SAE J 1995	hp	45,7	45,7
Speed	min-1	2.400	2.400
Speed adjustment 1	min-1	2.300	2.300
Speed adjustment 2	min-1	2.530	2.530
Electric equipment	V	12	12
Driven drum		front + rear	front + rear

Brakes

Service brake		hydrost.	hydrost.
Parking brake		hydromec.	hydromec.

Steering

Steering system		oscil.artic.	oscil.artic.
Steering method		hydrost.	hydrost.
Steering / oscillating angle +/-	grad	32/10	32/10
Crab walk	mm	0- 50	0- 50

Exciter system

Vibrating drum		front + rear	front + rear
Drive system		hydrost.	hydrost.
Frequency	Hz	50/56	50/56
Amplitude	mm	0,50	0,50
Centrifugal force	kN	39/48	45/57

Sprinkler System

Type of sprinkling		pressure	pressure
--------------------------	--	----------	----------

Capacities

Fuel	l	55,0	55,0
Water	l	310,0	310,0

Technical modifications reserved. Machines may be shown with options.

Standard Equipment

- Hydrostatic travel and vibration drive
- 2 scrapers per drum, spring loaded and tiltable
- Pressure sprinkler system with interval switch
- Multi function travel lever
- Multi-function display incl. operating hour meter
- Water level
- Electronic fuel gauge
- Emergency STOP
- Individual control, vibration
- Intelligent Vibration Control (IVC)
- Integrated storage compartment
- Sliding seat incl. double travel lever
- Seat contact switch
- 12V socket
- Working lights front and rear
- Vandalism protection
- Lockable engine hood made of composite material
- Lashing eyes, galvanized
- Single point lifting device
- Back-up alarm
- Battery disconnect switch

Optional Equipment

- *Foldable ROPS incl. seat belt
- Sun roof, rigid
- Sun roof, foldable with ROPS
- Weather protection for sun roof
- Weather protection cabin
- Seat heating
- ECONOMIZER with asphalt temperature display
- Temperature display
- BOMAG TELEMATIC
- Indicator and hazard lights
- Rotary beacon
- Optional lighting on ROPS
- Lighting for drum edge
- Environmentally compliant hydraulic oil
- Theft protection
- Edge cutter-right/left
- Gravel scrapper
- Hydraulically adjustable crabwalk (50mm)
- Pointer
- Special painting
- Backup warning buzzer with broadband technology
- Flow divider
- 2. Amplitude:0,2mm
- ECOSTOP
- Outside mirrors
- Anti-frost intake
- Tablet holder set
- JOBLINK measuring technology interface
- JOBLINK Bluetooth adapter
- BOMAP GPS antenna holder

* Standard delivery with CE conformity
(valid within European Union)#72



PRE 650 36 010

180225 Sa07

BOMAG
Hellerwald
D-56154 Boppard
P.O. Box 5162
Tel. (0)6742 - 1000
Fax (0)6742 - 3090

