

All-rounder

Wacker Neuson All-Wheel Dumpers
3001 • 4001 • 5001 • 6001

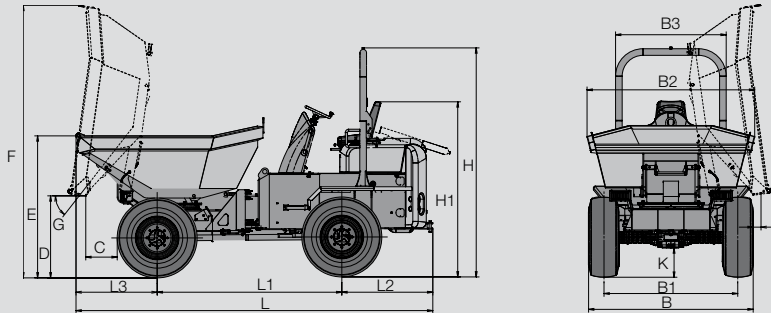

**WACKER
NEUSON**



6001s Front-tipping

DIMENSIONS	3001 (Front-Tipping)	3001 (Swivel-tipping)	4001 (Swivel-tipping)	4001 (Speed)	5001
B	1,785 mm	1,785 mm	1,795 mm	1,795 mm	1,920 mm
B1	1,490 mm	1,490 mm	1,480 mm	1,480 mm	1,580 mm
B2	1,860 mm	1,775 mm	1,740 mm	1,740 mm	1,990 mm
B3	1,310 (1,140**) mm	1,310 (1,140**) mm	1,300 mm	1,300 mm	1,310 mm
C	577 mm	600 mm	600 mm	600 mm	625 mm
D	260 mm	1,020 mm	1,030 mm	1,030 mm	1,160 mm
E	1,475 mm	1,475 mm	1,500 mm	1,500 mm	1,790 mm
F	2,220 mm	3,125 (2,200**) mm	3,200 mm	3,200 mm	3,630 mm
G	46 °	46 °	46 °	46 °	48 °
H *	2,670 mm	2,670 mm	2,700 mm	2,700 mm	2,830 mm
H1*	1,870 mm	1,870 mm	1,930 mm	1,930 mm	2,030 mm
H2**	2,610 mm	2,610 mm	-	-	-
I**	320 mm	320 mm	-	-	-
J	-	245 mm	270 mm	270 mm	250 mm
K	280 mm	280 mm	300 mm	300 mm	290 mm
L	3,980 mm	4,140 mm	4,200 mm	4,200 mm	4,390 mm
L1	1,960 mm	1,960 mm	1,960 mm	1,960 mm	2,110 mm
L2	1,160 mm	1,160 mm	1,215 mm	1,215 mm	1,150 mm
L3	860 mm	1,020 mm	1,025 mm	1,025 mm	1,130 mm
N**	1,350 mm	1,350 mm	-	-	-

* with ROPS roll-bar

** with cab

*** skip with low tipping height

3001
4001
5001
6001

	6001 (Front-tipping)	6001s (Swivel-tipping)
B	2,215 mm	2,215 mm
B1	1,800 mm	1,800 mm
B2	2,330 mm	2,250 mm
B3	1,490 (1140**) mm	1,490 (1140**) mm
C	433 mm	420 mm
D	346 mm	1,070 mm
E	1,771 mm	1,900 mm
F	2,550 mm	3,660 mm
G	53°	52°
H*	3,080 mm	3,080 mm
H1*	2,300 mm	2,300 mm
H2*	2,995 mm	2,995 mm
I**	320 mm	320 mm
J	-	100 mm
K	380 mm	380 mm
L	4,470 mm	4,810 mm
L1	2,485 mm	2,485 mm
L2	1,225 mm	1,225 mm
L3	760 mm	1,100 mm
N**	1,450 mm	1,450 mm

OPERATING-DATA	3001 (Front-tipping)	3001 (Swivel-tipping)	4001 (Swivel-tipping)	4001 (Speed)	5001	6001 (Front tipping)	6001 (Cab)	6001s (Swivel-tipping)	6001s (Cab)
Payload	3,000 kg	3,000 (2600***) kg	4,000 kg	3,500 kg	5,000 kg	6,000 kg	6,000 kg	6,000 kg	6,000 kg
Tare weight	2,410 kg	2,550 kg	2,730 kg	2,640 kg	3,220 kg	4,320 kg	4,520 kg	4,240 (4,450*) kg	4,440 kg
Skip capacity levelled	1,500 l	1,300 l	1,650 l	1,400 l	2,000 l	2,400 l	2,400 l	2,400 l	2,400 l
Skip capacity heaped	1,850 l	1,750 l	2,230 l	1,900 l	2,700 l	3,200 l	3,200 l	3,200 l	3,200 l
Skip capacity water level	1,160 l	900 l	1,150 l	1,130 l	1,400 l	1,880 l	1,880 l	1,880 l	1,880 l
ENGINE									
Make/Type	YANMAR 3TNV88	YANMAR 3TNV88	YANMAR 4TNV88	YANMAR 4TNV88	DEUTZ D2011	Deutz TD2011	Deutz TD2011	Deutz TD2011 (Deutz TCD2012*)	Deutz TD2011
Model	watercooled 3-cylinder Diesel engine	watercooled 3-cylinder Diesel engine	watercooled 4-cylinder Diesel engine	watercooled 4-cylinder Diesel engine	watercooled 4-cylinder Diesel engine	watercooled 4-cylinder Diesel engine	watercooled 4-cylinder Diesel engine	watercooled 4-cylinder Diesel engine	watercooled 4-cylinder Diesel engine
Power (Iso 3046/1)	26kW (35 hp)	26 kW (35 hp)	34.1 kW (46,1 hp)	34.1 kW (46,1 hp)	64.6 kW (87.8 hp)	64.6 kW (87.8 hp)	64.6 kW	64.6 kW (87.8 hp) (84 kW (115 hp)*)	64.6 kW (87.8 hp)
Displacement	1,642 cm ³	1,642 cm ³	2,189 cm ³	2,189 cm ³	3,619 cm ³	3,619 cm ³	3,619 cm ³	3,619 (4,038*) cm ³	3,619 cm ³
Operating speed	2,800 min ⁻¹	2,800 min ⁻¹	2,800 min ⁻¹	2,800 min ⁻¹	2,600 min ⁻¹	2,600 min ⁻¹	2,600 min ⁻¹	2,600 (2,220*) min ⁻¹	2,600 min ⁻¹
Exhaust emissions	ac. 97/68/EC, 3A	ac. 97/68/EC, 3A	ac. 97/68/EC, 3A	ac. 97/68/EC, 3A	ac. 97/68/EC, 3A	ac. 97/68/EC, 3A step 3a (EPA Tier 3)	ac. 97/68/EC, 3A step 3a (EPA Tier 3)	ac. 97/68/EC, 3A	ac. 97/68/EC, 3A
DRIVE CHARACTERISTICS									
Drive speed	0-7 kph/0-22kph	0-7kph/0-25kph	0-7kph/0-25kph	0-8kph/0-25kph	0-8kph/0-25kph	0-5kph/0-25kph	0-5kph/0-25kph	0-5kph/0-25kph	0-5kph/0-25kph
Centre-pivot angle	+/-37°	+/- 37°	+/- 37°	+/- 37°	+/- 37°	+/- 33°	+/- 33°	+/- 33°	+/- 33°
Oscillation	+/-15°	+/- 15°	+/- 15°	+/- 15°	+/- 15°	+/- 10,5°	+/- 10,5°	+/- 10,5°	+/- 10,5°
Turning radius outside	3,650 mm	3,650 mm	3,730 mm	3,730 mm	4,425 mm	5,200 mm	5,200 mm	5,200 mm	5,200 mm
Max. grade-ability	50 %	50 %	50 %	50 %	50 %	50 %	50 %	50 %	50 %
DRIVE									
Drive	hydrostatic automotive, drive via PTO gear to axles, electric drive direction selection								
Steering	hydrostatic articulated frame steering								
Tyres	11.50/80-15.3 Tractor profile	11.50/80-15.3 Tractor profile	11.50/80-15.3 Tractor profile	11.50/80-15.3 Tractor profile	12.5/80-18 Tractor profile	405/70-20; 14 Ply Tractor profile	405/70-20; 14 Ply Tractor profile	405/70-20; Tractor profile	405/70-20; Tractor profile
Service brake	via multi-disc brake in oil bath in front axle, hydraulically operated								
Parking brake	via multi-disc brake in oil bath in front axle, hydraulically operated								
HYDRAULICS SYSTEM									
Drive pump	Axial piston pump	Axial piston pump	Axial piston pump	Axial piston pump	Axial piston pump	Axial piston pump	Axial piston pump	Axial piston pump	Axial piston pump
Flow rate	126 l/min	126 l/min	112 l/min	112 l/min	145 l/min	184 l/min	184 l/min	184 (192*) l/min	184 l/min
Operating pressure	360 bar	360 bar	420 bar	420 bar	420 bar	420 bar	420 bar	420 (480*) bar	420 bar
Work pump	Gear pump	Gear pump	Gear pump	Gear pump	Gear pump	Gear pump	Gear pump	Gear pump	Gear pump
Flow rate	45 l/min	45 l/min	45 l/min	45 l/min	42 l/min	57 l/min	57 l/min	57 (52*) l/min	57 l/min
Operating pressure	220 bar	220 bar	175 bar	175 bar	220 bar	220 bar	220 bar	220 bar	220 bar
TANK CAPACITY									
Diesel tank	40 l	40 l	40 l	40 l	40 l	70 l	70 l	70 l	70 l
Hydraulic oil tank	48 l	48 l	48 l	40 l	48 l	70 l	70 l	70 l	70 l
ELECTRICS									
Voltage	12 V	12 V	12 V	12 V	12 V	12 V	12 V	12 V	12 V
Battery	88 Ah	88 Ah	88 Ah	88 Ah	88 Ah	100 Ah	100 Ah	100 Ah	100 Ah
Alternator	40 A	40 A	40 A	40 A	40 A	55 A	55 A	55 (95*) A	55 A
Starter	1.7 kW	1.7 kW	2.0 kW	2.1 kW	2.3 kW	2.3 kW	2.3 kW	2.3 kW	2.3 kW
NOISE LEVELS									
Noise LWA (acc. 2000/14/EC)	101 dB(A)	101 dB(A)	101 dB(A)	101 dB(A)	101 dB(A)	102 dB(A)	102 dB(A)	102 (103*) dB(A)	102 dB(A)

* Power Version
*** skip with low tipping height